

# **FORCE**™ DUST COLLECTORS



**Stronger. Better. CLEANER.**



# Stronger. Better. **CLEANER.**

## Micro Air® **FORCE™** Dust Collectors The Next Generation Of CLEAN Air Systems



### **Unrivaled Cleaning Technology**

**FORCE™** Dust Collectors are designed for maximum dust filtration, operating at higher efficiency levels and lower cost. The Exclusive Roto-Pulse® cartridge cleaning system extends filter life and requires less compressed air, reducing maintenance and increasing dust collection efficiency compared to typical backflush systems.

### **New Hinged Door Filter Access**

Heavy-Duty hinged steel doors provide easy access for cartridge inspection, removal and replacement.

### **True Ledgeless Construction**

Micro Air **FORCE™** dust collectors have a true ledgeless design compliant with NFPA and OSHA standards that eliminates dust build-up improving performance.

### **Compact Modular Design**

Engineered with space in mind **FORCE™** dust collectors have a reduced footprint saving valuable floor space, enhancing mobility and product versatility for stand-alone and multi-unit installations.

### **Rigid Long-Lasting Fabrication**

Manufactured for a variety of applications the Micro Air **FORCE™** is constructed from 12 gauge galvaneal steel for maximum durability and performance.

### **Increased Capacity**

**FORCE™** units are rated at +/- 30" of internal static pressure improving overall function of the unit.







Internal mounted valve system and components.



Filters available in multiple sizes and configurations, standard with fire retardant coating.

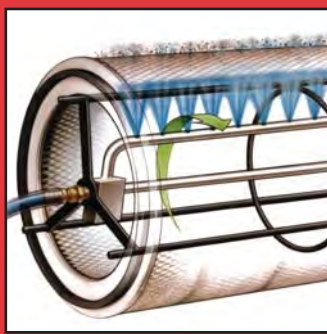

Exclusive Roto-Pulse® Design extends filter life reducing replacement costs.

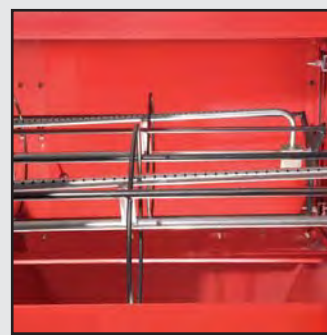

Incremental revolutions uniformly clean 100% of cartridge surface.

## ***New Robust Valve System***

Long life valve components have a 20 year life expectancy rated to (-40 °F), no additional heating elements for excessively hot or cold climate applications.

## ***Indoor And/Or Outdoor Installations***

Tested and rated for interior and exterior use, **FORCE™** dust collection systems do not require any additional upgrades or modifications for exterior applications.

## ***Full Electrical Control Package***

Full electrical control package including motor starter, overload switches, start/stop and optional fused disconnect. One-stop shop for all sourcing component needs.

## ***Dust Collector Exterior Appearance***

A choice of paint options to suit cost sensitive installations, **FORCE™** dust collectors are offered in baked enamel, powder coat and epoxy coat finishes.

## ***Reduced Noise Exposure***

Roto-Pulse® cleaning is quieter, typically 15dBA quieter than reverse pulse cleaning systems and requires less compressed air, thus extending the life of the filters and compressor.

## ***Improved Air Delivery System***

Integrated surge tank provides greater efficiency, improved valve system is rated for 5 million cycles with no maintenance required, **FORCE™** collectors consume 2.7 scfm-5.4 scfm of compressed air, compared to a competitive reverse pulse system requiring 7.0 scfm-20.0 scfm.

## ***Enhanced Support System***

New support system is easier to install, tested for a variety of environmental rigors and requires no cross-bracing for seismic zones 1, 2 and 3.

## ***Best Industry Warranty***

- 10yr - Major structural components
- 5yr - Roto-Pulse®
- 1yr - All other components and accessories

## **Expanded Surge Tank**

**Provides optimal air delivery to the cleaning system, increases efficiency and compensates for sub-standard compressed air systems.**



# Dust Collector Specifications

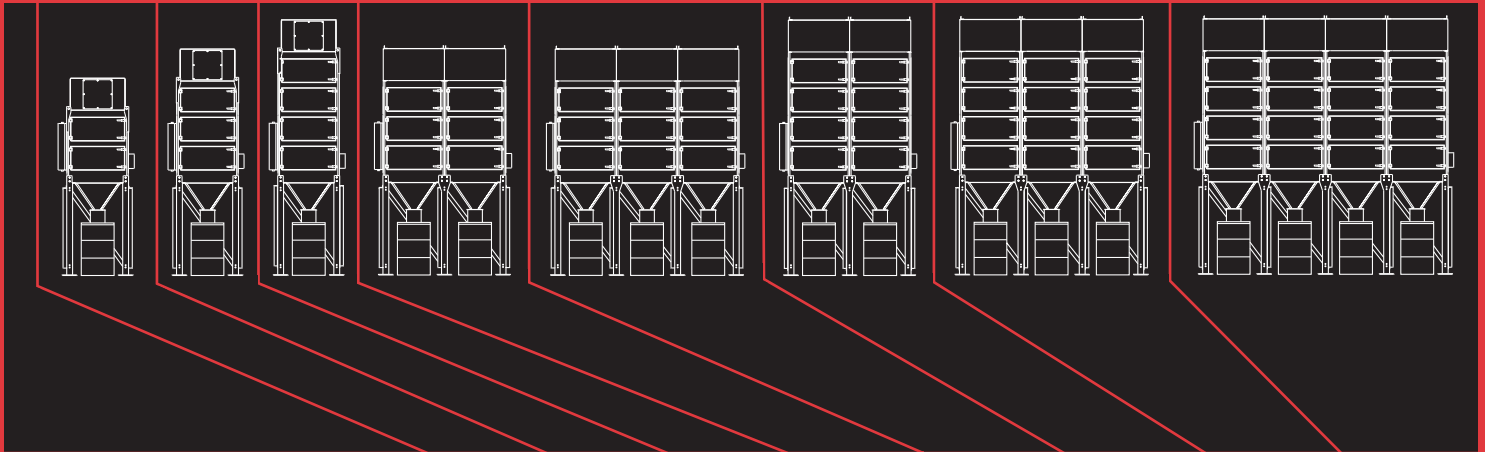

MODEL	FRP4	FRP6	FRP8	FRP6-2	FRP6-3	FRP8-2	FRP8-3	FRP8-4
No. of Filters	4	6	8	12	18	16	24	32
Nano & 80/20 Filter Area* sq. ft.	1,000	1,500	2,000	3,000	4,000	4,500	6,000	8,000
Spunbond & PTFE Filter Area ** sq. ft.	600	900	1,200	1,800	2,700	2,400	3,600	4,800
Compressed Air Requirements	2.7 scfm	2.7 scfm	2.7 scfm	2.7 scfm	2.7 scfm	2.7 scfm	5.4 scfm	5.4 scfm
No. of Valves	2	3	4	6	9	8	12	16
Height (in) w/o inlet plenum - short legs	66	86	106	86	86	106	106	106
Height (in) w/inlet plenum - short legs	88	108	128	110	110	130	130	130
Height (in) w/o inlet plenum - long legs	114	134	154	134	134	154	154	154
Height (in) w/inlet plenum - long legs	136	156	176	158	158	178	178	178
Width (in)	53	53	53	95	136	95	136	179
Depth (in)	48	48	48	48	48	48	48	48

## STANDARD FEATURES

<b>Construction</b>	12 gauge steel
<b>Paint</b>	Industrial grade crimson red, textured baked enamel or epoxy coat, inside & outside
<b>Compressed Air</b>	Requires 90 PSI for incremental Roto-Pulse® cleaning system
<b>Wind Load</b>	Rated up to 160mph with angle bracing; rated up to 115mph without angle bracing
<b>Control Panel/ Electrical</b>	All package collectors come complete with factory installed motor starter, overload protection, control transformer (Intelli-Touch-optional), pushbutton start/stop switches and solid state timer board with fuse protection.
<b>Housing Pressure</b>	Rated to +/- 30 inches w.c.
<b>Filtration Efficiency</b>	Optional selections between MERV 11 and 16 filtration efficiency levels
<b>Collection Options</b>	Dust tray or hopper
<b>Seismic Data</b>	$S_s = 0.551$ $S_1 = 0.132$



## APPLICATIONS











METALWORKING • COMPOSITES • WOODWORKING • FOOD PROCESSING • CHEMICAL • PHARMACEUTICAL • PULP & PAPER

P.O. Box 1138 • Wichita, KS 67201 • 316.946.5875 • FAX 316.219.2995 • Toll Free: 1.866.566.4276

e-mail: [info@microaironline.com](mailto:info@microaironline.com) • [www.microaironline.com](http://www.microaironline.com)

# Dust Collector Options



	<b>Fans</b>	Rear mounted
		Top mounted
		Custom orientations and configurations
	<b>Voltage</b>	208/230 Volt, Three phase
		460 Volt, Three phase
		575 Volt, Three Phase
	<b>Filtration</b>	80% Cellulose/20% Spunbond Polyester fire retardant blend- for most applications including metalworking, pharmaceutical, smoke and general industrial.
		100% Spunbond Polyester - for fibrous and agglomerative dust such as woods, plastics, composites, etc.
		100% Hydro-Olieophobic Treated Spunbond Polyester - for oily particulate or high humidity applications.
		PTFE membrane cartridges - for food and chemical applications
		Aluminized cartridges
		95% DOP HEPA afterfilter
		99.97% DOP HEPA afterfilter
		Absolute afterfilter - for regulated dust
		Additional specialized application filters
	<b>Collection</b>	Standard hopper
		Dust tray
	<b>Exhaust</b>	Silencer
		Motor shroud kit
	<b>Legs</b>	Long leg kit - for use with hopper or silencer, no cross-bracing required
		Short leg kit - low profile design with dust tray, no cross-bracing required
	<b>Explosion Control</b>	Explosion vent kit
		Backblast dampers
		Inlet/Outlet isolation
		Sprinkler ports, rotary valves
	<b>Others</b>	Magnahelic guage
		Photohelic guage
		Intelli-Touch energy savings controls
		Multiple filter monitoring devices
		Hard ducted barrel lid kit
		Inlet Plenum
		Spark arrestors - for hazardous applications

## ACCESSORIES

SOURCE CAPTURE ARMS • INVERTERS • REGULATORS • SILENCERS • SAFETY FILTER • DRUMS



P.O. Box 1138 • Wichita, KS 67201 • 316.946.5875 • FAX 316.219.2995 • Toll Free: 1.866.566.4276

e-mail: [info@microaironline.com](mailto:info@microaironline.com) • [www.microaironline.com](http://www.microaironline.com)



# Roto-Pulse® Cleaning Systems

## Stronger. Better. CLEANER.

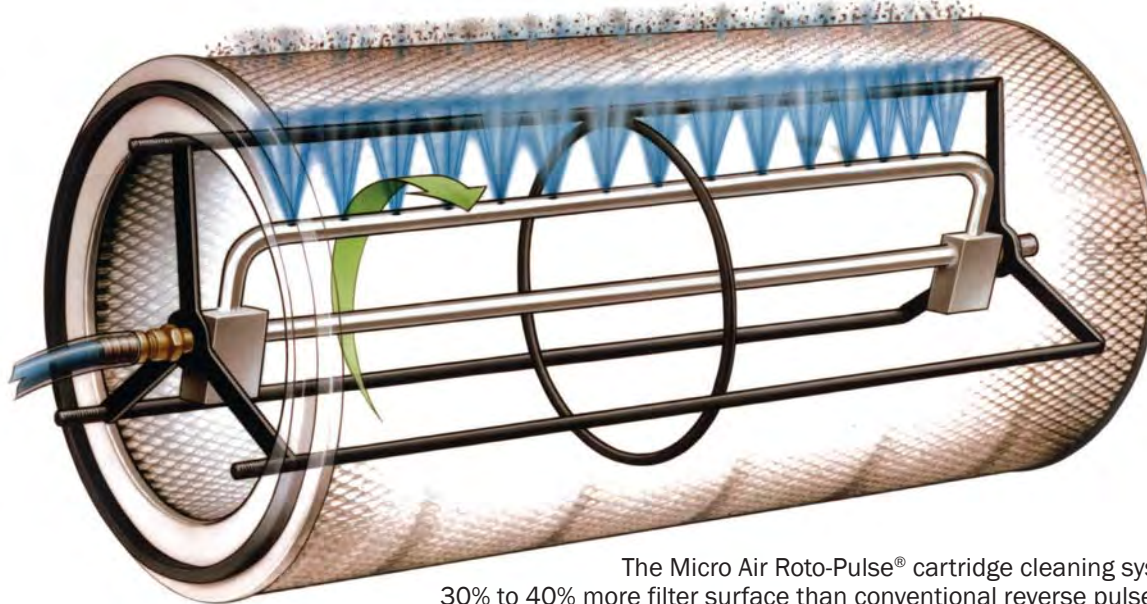

The Micro Air Roto-Pulse® cartridge cleaning system uniformly cleans 30% to 40% more filter surface than conventional reverse pulse (backflush) systems, all while running quieter and using less compressed air. It extends the life of your filters, your compressor and reduces your risk of violating OSHA sound level standards. Our 5 year limited warranty on Roto-Pulse® assures confidence in the system design.

### Micro Air Roto-Pulse® Cartridge Cleaning System

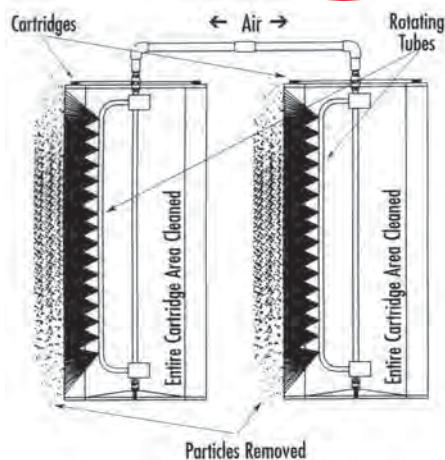

Air is pulsed into a specially designed stainless steel rotating tube with pre-drilled holes. The tube incrementally rotates, distributing the pulse of air across the length of the inside surface of the cartridge, dislodging clogged dirt from the outside of the cartridge. The number of increments per revolution can be adjusted, as well as the time between pulses, for maximum flexibility.

### Typical Air Cleaner Backflush System

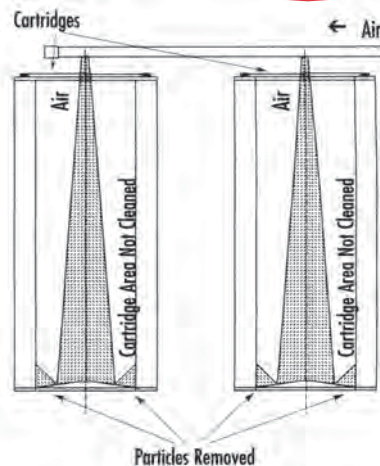

Air enters cleaning pipe and is pulsed into cartridge out of each filter. The air hits only the back corners of the cartridge resulting in inefficient cleaning.



FRP8-2 - 16 cartridge collector with top mounted fan.



NFPA/OSHA compliant explosion vent.

# Dust Collector Operation (Typical)

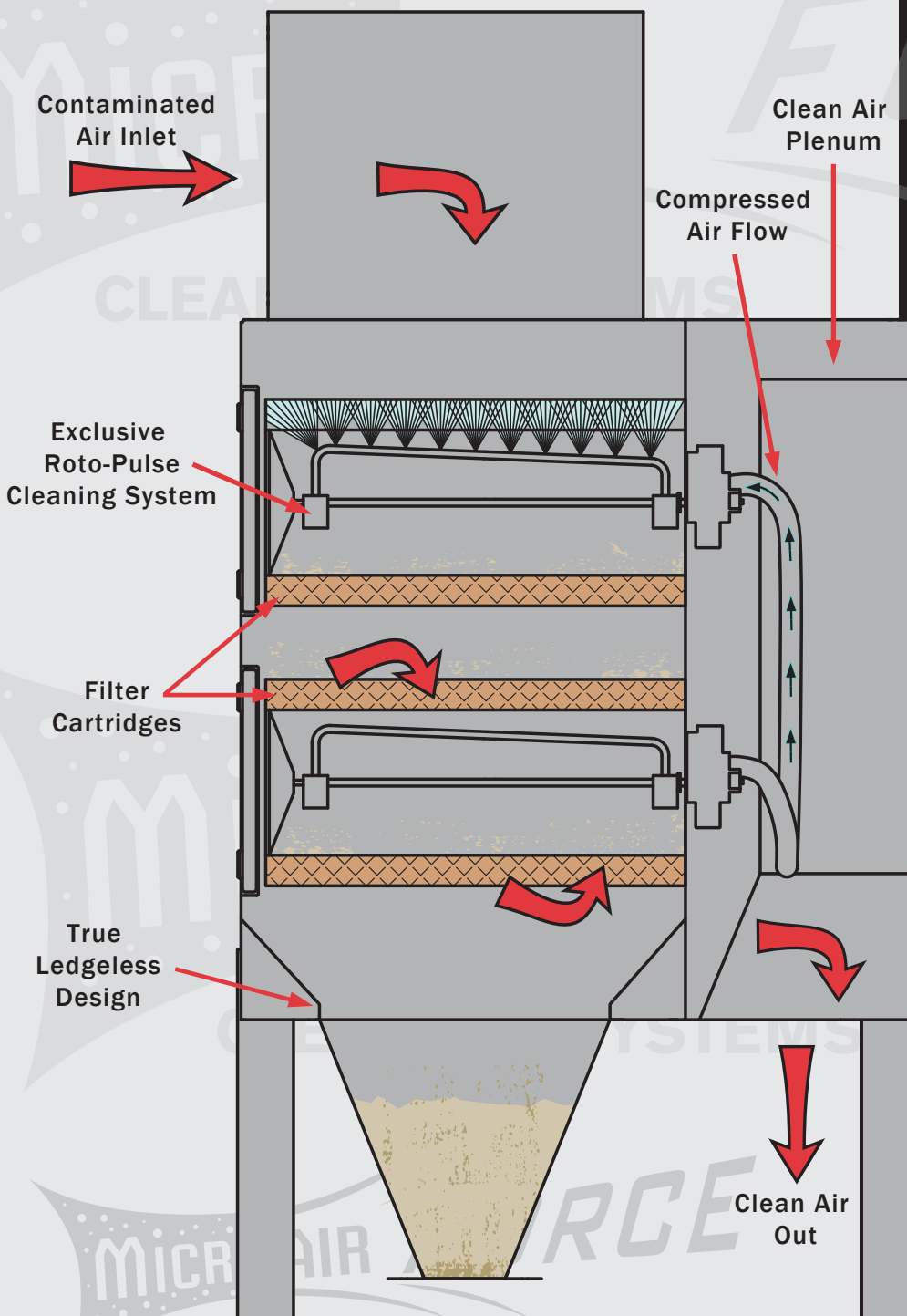

New **FORCE™** ledgeless design helps to eliminate combustible dust build-up, compliant with NFPA/OSHA industry standards.



Dust-laden air is drawn in at the top inlet, then flows downward through the cartridges. Clean air is exhausted at the bottom of the unit.

(Note: Bolt-together models that may use a top mounted fan; the clean air is exhausted at the top of the unit.)



FORCE RP Collectors - engineered for easy filter access with new door and latch design.

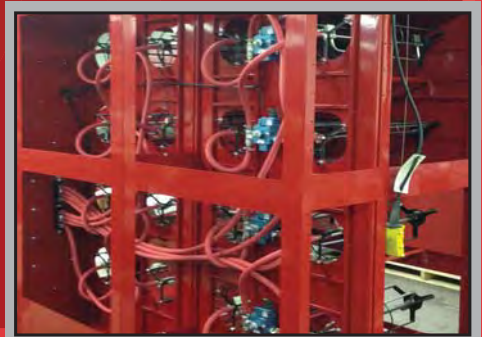

FRP8-2 – new robust valve system, internally mounted.





## INTELLI-TOUCH ENERGY SAVINGS CONTROL PANEL

- Reduces energy consumption by using only the brake horsepower needed to maintain the specified CFM. Built in variable frequency drive automatically slows or speeds the motor RPM based on CFM needed at the running static pressure.

- Reduces peak energy consumption costs by utilizing a soft-start or slow ramp up of motor speed, eliminating sudden surges of power usage.
- Increases expected filter life by automatically adjusting filter cleaning process based on system needs, while dramatically reducing compressed air usage.
- Allows for quieter operation through utilization of lower fan speeds.
- Built-in pulse on demand feature and static monitoring system eliminates the need for Magnahelic or Photohelic gauge.
- Eliminates the need for external dampers or slide gates in ductwork. Simply touch the arrow on the touchscreen to adjust CFM.
- Built-in diagnostics feature tracks pertinent data such as CFM, static pressure, amp draw, RPM pulse settings and hours of operation.
- Capability to upsize unit for future expansions.
- Application specific (plasma, laser, wood-working, grinding, etc.) set-up feature reduces installation time.

Investment payback in as little as 6 months depending on energy costs and application usage. Visit our website, [www.microaironline.com](http://www.microaironline.com), and use the savings calculator to see how fast of a payback you can expect.

# MICRO AIR®

## Stronger. Better. CLEANER

For more than 45 years, Micro Air has manufactured clean air systems that are simple to use and remarkably efficient.



Call us today, or visit:  
[www.microaironline.com](http://www.microaironline.com)

for a **FREE EVALUATION AND PRICE QUOTE.**

### APPLICATIONS

- **WELDING** smoke and fumes
- **MACHINING** mist and smoke
- **METALWORKING** dust
- **PROCESS** dust and powder
- **COMMERCIAL** applications

DISTRIBUTED BY:



Source Capture



Clean Air Booths



Ambient Air Cleaners



Wet Collectors



Mist Collectors



Dust Collectors



## Stronger. Better. CLEANER.

P.O. Box 1138 • Wichita, KS 67201  
316.946.5875 • FAX 316.219.2995  
e-mail: [info@microaironline.com](mailto:info@microaironline.com) • [www.microaironline.com](http://www.microaironline.com)

Toll-Free  
1.866.566.4276



Litho in U.S.A. ©2015 Metal-Fab, Inc. Form No. L2820-9/15